

MASELEC
MLA-3
Multi Band Compressor



- | | | | | | |
|---|-------------------------------------|---|-------------------------|---|---------------------------------|
| ① | Low-to-Mid crossover Frequency | ⑩ | Low Frequency Release | ⑲ | High Frequency Attack |
| ② | Mid-to-High crossover Frequency | ⑪ | Low Frequency Threshold | ⑳ | High Frequency Release |
| ③ | Master Threshold (all frequencies) | ⑫ | Mid Frequency Ratio | ㉑ | High Frequency Threshold |
| ④ | Linking of Low-Mid-High Side-Chains | ⑬ | Mid Frequency Gain | ㉒ | High Frequency Side-Chain Boost |
| ⑤ | Left channel Input Gain | ⑭ | Mid Frequency Attack | ㉓ | Gain Reduction Bargraph Meters |
| ⑥ | Right channel Input Gain | ⑮ | Mid Frequency Release | ㉔ | Power On/Off |
| ⑦ | Low Frequency Ratio | ⑯ | Mid Frequency Threshold | ㉕ | Output Selector Tri Colour LED |
| ⑧ | Low Frequency Gain | ⑰ | High Frequency Ratio | ㉖ | Output Gain |
| ⑨ | Low Frequency Attack | ⑱ | High Frequency Gain | | |

Note: All rotary controls are switches using discrete resistors.

DESCRIPTION

The input signal is split into three frequency-bands. Each band is passed through a stereo compressor where gain and compression can be altered. The outputs of the compressors are then re-combined and fed to the outputs.

There are four different frequencies for each of the two crossovers that can be separately selected for the low-to-mid and the mid-to-high bands.

The three frequency-band compressors have separate controls so that different parts of the audio spectrum can be adjusted and tuned.

With separate gain controls for each frequency-band, the MLA-3 can be used as an equalizer.

You can always adjust the controls for the separate frequency bands to different settings. There is no *technical* reason why they should be the same for all frequencies.

Overall Input and Output gain controls make it easy to set up for different operating levels.

Inputs

The inputs are electronically balanced, virtually ground floating, making them perform as if they are transformer coupled, but without the associated colouration, low frequency distortion and restricted bandwidth.

The input impedance is 100kohm. Maximum input level is $>+29\text{dBu}$ (balanced).

Outputs

The outputs are electronically balanced and can deliver $>+28\text{dBu}$ into 600ohm (balanced). Output impedance is 33ohm (balanced and unbalanced).

The inputs and outputs can be unbalanced by simply grounding either pin 2 or pin 3.

Block Diagram

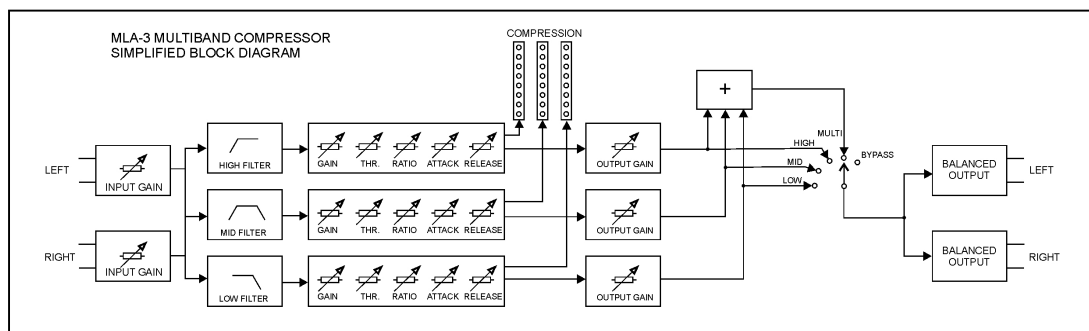

MASTER and INPUT SECTION

Sets the **crossover frequency** between LOW and MID bands.
Slope: 6dB/octave

Master Threshold:
Sets the operating point for the three individual frequency-band thresholds.

LEFT input Gain:
Adjusts the gain before the three compressors.
-5dB to +5dB

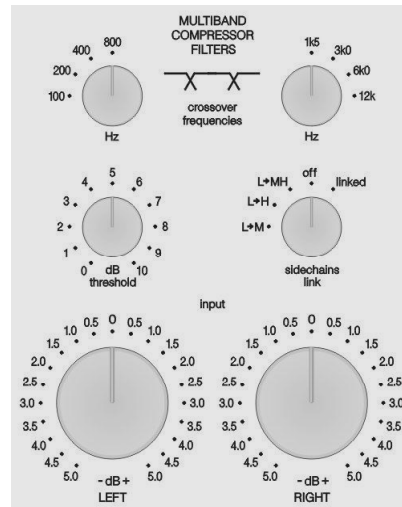

Sets the **crossover frequency** between MID and HIGH bands.
Slope: 6dB/octave

Sidechains Link:
Links the sidechains of the frequency bands.
It is not a stereo link.
See below.

RIGHT input Gain:
Adjusts the gain before the three compressors.
-5dB to +5dB

Crossover Frequencies

The crossover between the frequency bands can be set to four different frequencies for both the lower and higher transitions.

The filters are passive with 6 dB/octave slopes, which ensure smooth and exceptionally accurate summation of the bands and with minimum colouration and a very flat frequency response.

Master Threshold

Use the Master Threshold to set the point at which the three frequency-band thresholds are in convenient positions for the amount of compression that you want.

CW positions increase the thresholds (which would lead to less compression).

Sidechains Link

This control links the side-chains from the different frequency bands (it is not a stereo link).

- L->M** LOW band compression is fed to the MID band regardless of any other setting. This can be used to get bass frequencies to duck and 'pump' the MID band.
Note: MID compression is not fed (the other way) to the LOW band.
- L->H** LOW band compression is fed to the HIGH band regardless of any other setting. Use this setting to get bass frequencies to duck and 'pump' the HIGH band.
Note: HIGH compression is not fed (the other way) to the LOW band.
- L->MH** LOW band compression is fed to the MID and HIGH bands regardless of any other setting. Use this setting to get bass frequencies to duck and 'pump' the MID and HIGH bands.
Note: MID and HIGH compression is not fed (the other way) to the LOW band and the HIGH and MID sidechains are not linked
- Off** All three frequency bands are separated (normal operation).
- Linked** All three frequency bands are linked. With this setting all frequencies are compressed with the same amount. This makes the MLA-3 act (and sound) like a normal stereo compressor. However, you can use the three sets of individual frequency-band controls to set how different frequencies affect the overall compression.
You can use the individual gain controls to equalize the programme in all five modes.

Input Gain

The input gain, before the compressors, can be adjusted between -5 dB and +5 dB in ½ dB steps. Separate controls for Left and Right channels.

LOW FREQUENCY CONTROLS

LOW frequency Ratio.

1:1 = No compression
1.4:1 to 6:1 ratios

LOW frequency Attack.

Six different attack times.
1 msec to 200 msec.

LOW frequency Threshold.

-10dB to +10dB

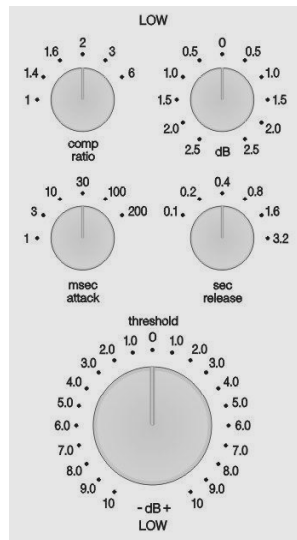

LOW frequency Gain.

Use for makeup gain or equalization.
-2.5dB to +2.5dB

LOW frequency Release.

Six different release times.
100 msec to 3.2 sec.

LOW frequency Ratio

Six positions: 1:1 to 6:1.

The ratio control also varies the threshold to compensate for the otherwise less amount of compression with lower ratios. The 1:1 position can be used to switch off the LOW compression.

LOW frequency Attack

The attack time can be varied between 1 msec and 200 msec in six steps.

For longer attack times you will probably have to adjust the threshold to a lower value (CCW) to maintain some compression.

LOW frequency Gain

The gain of the low frequency band can be varied between -2.5 dB and +2.5 dB in ½ dB steps.

The net effect is similar to a passive equalizer.

This control does not affect the compression.

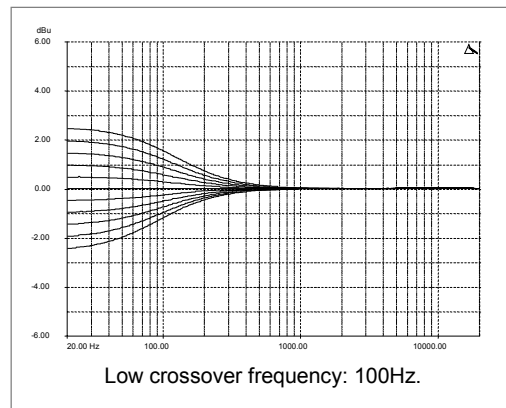

LOW frequency Release

The release time can be varied between 100 msec and 3.2 sec in six steps.

Programme dependent circuits reduce the distortion and speed up the release for short duration transients.

For less overall 'equalized' sounds; try shorter release times.

MID FREQUENCY CONTROLS

MID frequency Ratio.

1:1 = No compression
1.4:1 to 6:1 ratios

MID frequency Attack.

Six different attack times.
0.5 msec to 100 msec.

MID frequency Threshold.

-10dB to +10dB

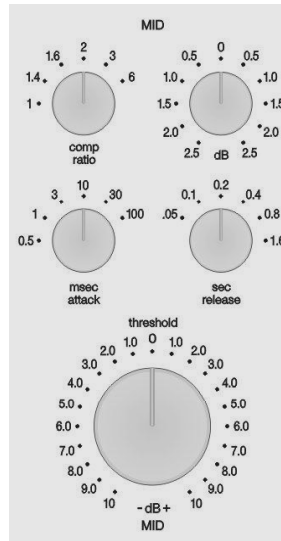

MID frequency Gain.

Use for makeup gain or equalization.
-2.5dB to +2.5dB

MID frequency Release.

Six different release times.
50 msec to 1.6 sec.

MID frequency Ratio

Six positions: 1:1 to 6:1.

The ratio control also varies the threshold to compensate for the less amount of compression with lower ratios. The 1:1 position can be used to switch off the MID compression.

MID frequency Attack

The attack time can be varied between 0.5msec and 100 msec in six steps.

For longer attack times you will probably have to adjust the threshold to a lower value, CCW, to maintain some compression.

MID frequency Gain

The gain of the mid frequency band can be varied between -2.5 dB and +2.5 dB in ½ dB steps.

The net effect is similar to a passive equalizer.

This control does not affect the compression.

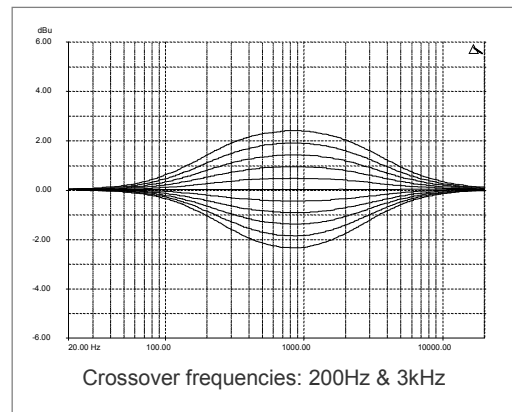

MID frequency Release

The release time can be varied between 50 msec and 1.6 sec in six steps.

Programme dependent circuits reduce the distortion and speed up the release for short duration transients.

For less overall 'equalized' sounds; try shorter release times.

HIGH FREQUENCY CONTROLS

HIGH frequency Ratio.

1:1 = No compression
1.4:1 to 6:1 ratios

HIGH frequency Attack.

Six different attack times.
0.3 msec to 100 msec.

HIGH frequency Threshold.

-10dB to +10dB

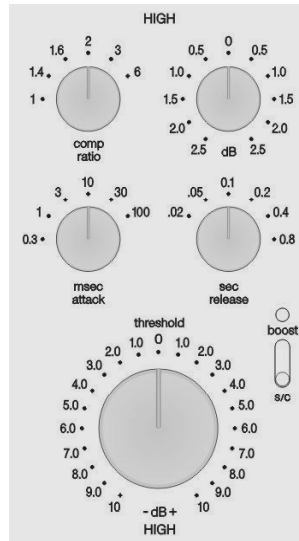

HIGH frequency Gain.

Use for makeup gain or equalization.
-2.5dB to +2.5dB

HIGH frequency Release.

Six different release times.
20 msec to 0.8 sec.

High Frequency Side Chain Boost.

Increases high frequency compression.
Red LED indicator

HIGH frequency Ratio

Six positions: 1:1 to 6:1.

The ratio control also varies the threshold to compensate for the less amount of compression with lower ratios. The 1:1 position can be used to switch off the HIGH compression.

HIGH frequency Attack

The attack time can be varied between 0.3 msec and 100 msec in six steps.

For longer attack times you will probably have to adjust the threshold to a lower value, CCW, to maintain some compression.

HIGH frequency Gain

The gain of the high frequency band can be varied between -2.5 dB and +2.5 dB in ½ dB steps.

The net effect is similar to a passive equalizer.

This control does not affect the compression.

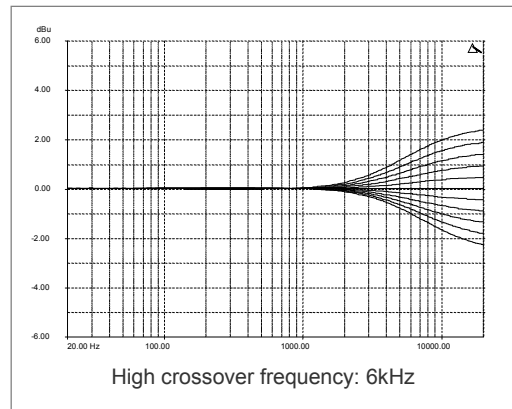

HIGH frequency Release

The release time can be varied between 20 msec and 0.8 sec in six steps.

Programme dependent circuits reduce the distortion and speed up the release for short duration transients.

For less overall 'equalized' sounds; try shorter release times.

S/C Boost

A high frequency boost in the side chain makes higher frequencies compress more.

High frequencies are usually at relatively low levels or short duration transients. For such higher frequencies to compress, you would otherwise have to lower the threshold, which could cause excessive compression from frequencies that are closer to the crossover frequency.

COMPRESSION METERS

Compression (gain reduction) is shown on three bargraph meters with eleven blue LEDs.

The range is 0dB to 8dB in ½ dB and 1 dB steps.

0dB indicates that there is some compression (signal above threshold).

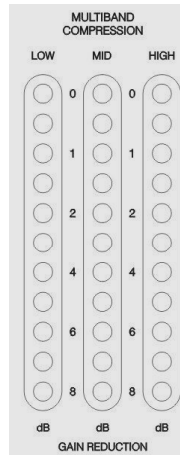

OUTPUT SECTION

Output Select,
Multiband output or individual frequency bands

Output Gain.
Adjusts the gain for both channels *after* the compressors.
-5dB to +5dB

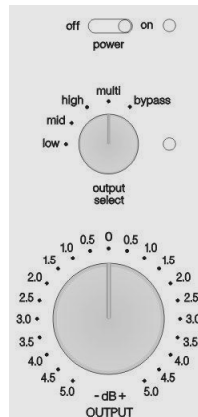

Power on/off
Blue LED indicator

Tri-colour LED
Red: bypass
Green: multi
Orange: low, mid or high

The MLA-3 is **automatically bypassed** when the power is switched off.

Output Select

- low: The output from the LOW frequency compressor is fed to the output.
- mid: The output from the MID frequency compressor is fed to the output.
- high: The output from the HIGH frequency compressor is fed to the output.
- multi: The output of the Multiband Compressor is fed to the output.
- bypass: The whole unit is galvanically bypassed.

Monitoring the outputs from the individual frequency bands can make it easier to select crossover frequencies and setting up the three compressors.

The individual outputs can also be used to create band-pass sounds for effects.

Output Gain

The output gain, post compressors, can be adjusted between -5dB and +5dB in ½ dB steps

FILTERS

The filters are passive, with a slope of 6dB/octave. This is the optimum configuration for accurate summing of the three bands.

LOW frequency Filter

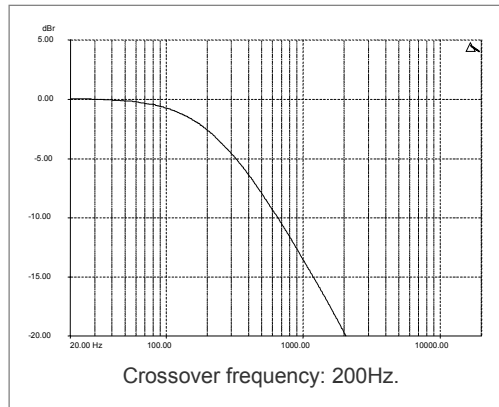

MID frequency Filter

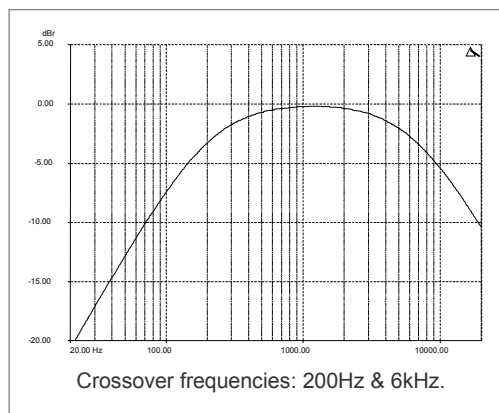

HIGH frequency Filter

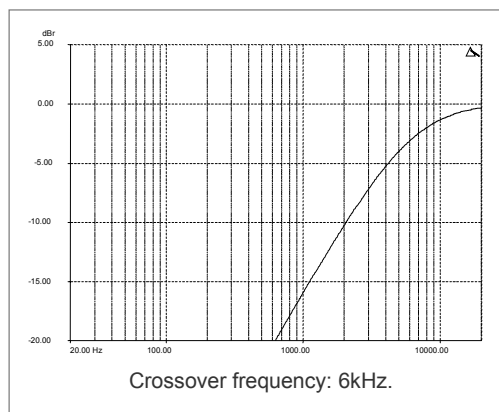

Multiband output (3-band sum)

All three filters set to the same gain: -2.5dB to +2.5dB
(11 x 1/2dB steps)

Frequency response is absolutely flat.

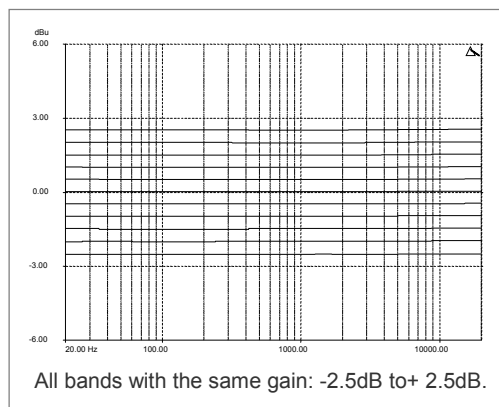

COMPRESSION

LOW frequency Compression

Low 6:1
Mid 1:1
High 1:1

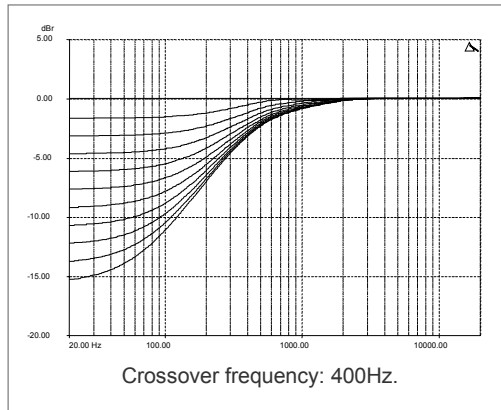

MID frequency Compression

Low 1:1
Mid 6:1
High 1:1

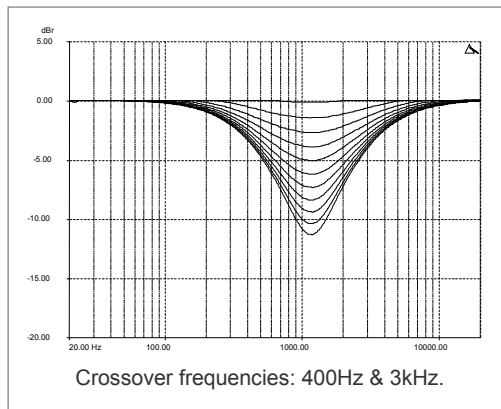

HIGH frequency Compression

Low 1:1
Mid 1:1
High 6:1

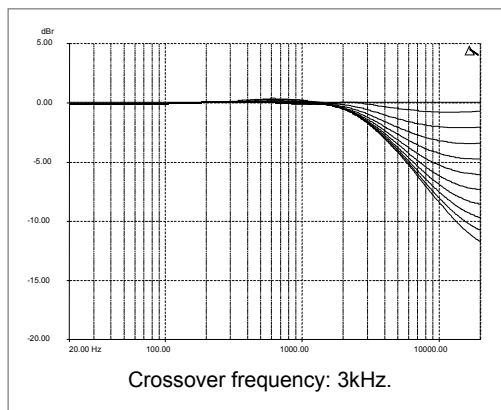

High frequency Compression with and without S/C boost

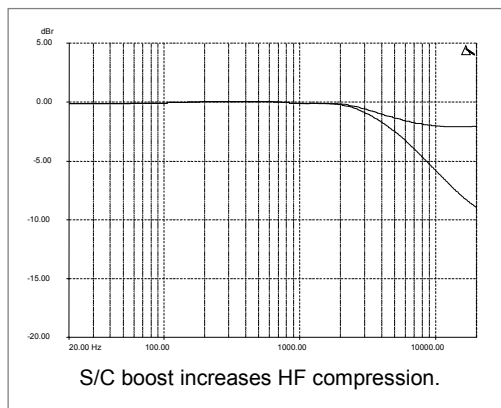

Compression

Multiband output compressed:

All three frequency bands set to the same threshold and ratio.

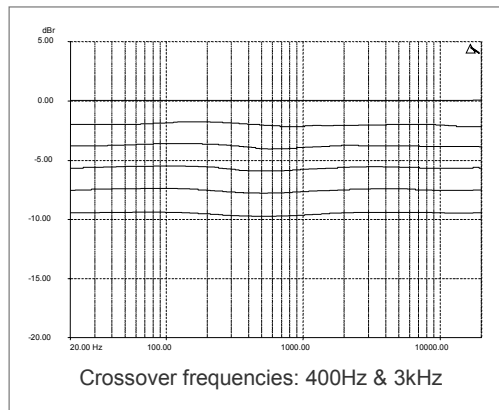

Compression Ratios:

All three frequency bands set to the same threshold and ratio.

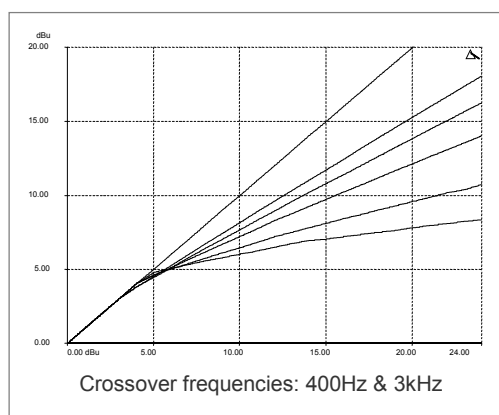

Technical Specification

Input Impedance	100 kohm
Maximum input level	+29dBu (0dBu = 0.775V)
Thresholds	-10dBu to +20dBu
Typical THD (ratio 1:1)	<-90dB
Bandwidth	greater than 1Hz to 500kHz
Typical Noise	-90dBu
Maximum Output level	+28dBu
Output impedance	33 ohm

Subject to change without notice.